

DIMENSIONS

All dimensions are approximate. Dimensions may vary with bucket and tire choice. Refer to operating specifications.

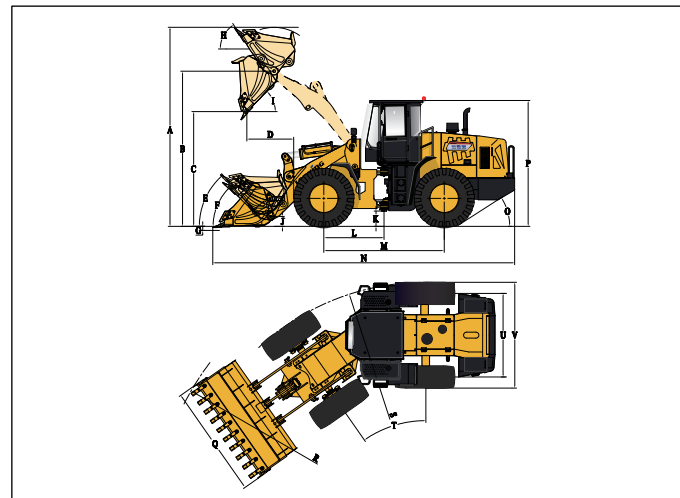

NO.	DESCRIPTION	UNIT	DIMENSIONS
A	Overall Height – Bucket Raised	mm	5323
B	Bucket Pin Height at Max. Lift	mm	4163
C	Dump Clearance at Max. Lift (45°)	mm	3080
D	Reach at Max. Lift and 45° Dump	mm	1256
E	Rack Back Angle at Carry	°	48
F	Rack Back Angle at Ground	°	45
G	Digging Depth	mm	50
H	Rack Back Angle at Max. Lift	°	53
I	Dump Angle at Max. Lift	°	45
J	Carry Height	mm	400
K	Ground Clearance	mm	409
L	Center Line of Front Axle to Hitch	mm	1615
M	Wheel Base	mm	3230
N	Overall Length	mm	8150
O	Departure Angle	°	32
P	Height to Top of Cab	mm	3380
Q	Overall Width over Bucket	mm	3010
R	Min. Turning Radius over Bucket	mm	7106
S	Min. Turning Radius over Tires	mm	6537.5
T	Steering Angle – Left/Right	°	35
U	Width at Tread Center	mm	2240
V	Overall Width over Tires	mm	2835

OVERALL DATA

Bucket Capacity	3.0m³
Rated Payload	5000kg
Operating Weight	17200±300kg
Traction Force	155±3kN
Breakout Force	170±3kN
L×W×H	8150×3010×3380mm

ENGINE&ELECTRICAL SYSTEM

Maker/Model	WEICHAI/WD10G220E21
Emission Standard	National II
Engine Type	4 Stroke, Turbocharged, Water-cooled, Direct Injection, Diesel Engine
Rated Power	162kW(220hp)/2200rpm
Maximum Torque	860N·m/1400-1600rpm
Bore x Stroke (mm)	126×130
No. of Cylinders/Displacement	6/9.726L
Compression Ratio	17.0
Air Cleaner	Three Stage Air Cleaner with Cyclone Pre-cleaner
Alternator	55Amp
Battery	2-24V/120Ah
Starting Motor	24V/7.5kW
Heating Capacity (W)-OPTIONAL	5000W
Cooling Capacity (W)-OPTIONAL	4700W

DRIVE TRAIN

Transmission Type	Planetary Powershift Transmission				
Shift Type	Mechanical Powershift Control				
Pressure of Transmission	1.2-1.5MPa				
Torque Converter Type	Single-stage, Duo-turbine, 4-element				
Torque Ratio	4.0				
Axles	Rigid Front Axle&Oscillating Rear Axle				
Rear Axle Oscillation (°)	±10°				
Differential	Conventional				
Main Reducer	Spiral Bevel, 1-stage Reduction				
Final Reducer	Planetary Reduction				
Tire	23.5-25 L-3 16PR TT				
Travel Speeds	km/h	1st	2nd	3rd	4th
Forward	11.5	36			
Reverse	16				

BRAKE SYSTEM

Service Brake	Single Circuit Caliper, Dry Brake
Setting Pressure	0.70-0.78MPa
Parking Brake	Air Actuated Caliper Brake
Emergency Brake	Air Actuated Caliper Brake

STEERING SYSTEM

Type	Hydraulic Load Sensing System	
Pump	Gear Pump, 176L/min • 2200rpm	
System Pressure	15MPa	
Cylinder	Type	Double Acting
	Bore x Stroke	2-100×324mm
Steering Angle		±35°

HYDRAULIC SYSTEM

Type	Single-lever(Joystick) Control			
Pump	Gear Pump, 220L/min • 2200rpm			
Control Valve	2 Spool (Bucket&Boom)			
System Pressure	16MPa			
Cylinder	Lift Cylinder	2-180×721mm		
No.-Bore x stroke	Tilt Cylinder	1-200×563mm		
Joystick Control Pressure		2.5MPa		
Cycle Time (Sec)	Raise	Dump	Lower	Total
	6.0	1.0	4.0	11.0

SERVICE REFILL CAPACITY

Fuel Tank (L)	285L
Hydraulic Tank (L)	270/275(3 rd Spool for Auxiliary Function)L
Crankshaft (L)	20L
Transmission (L)	46L
Front Axle/Rear Axle (L)	28L/28L

STANDARD EQUIPMENT

WEICHAI Engine	Air Actuated Caliper Brake
LONKING Transmission	Standard Lift&Bucket (3.0m³)
Mechanical Powershift Control	ROPS&FOPS Cabin
LONKING Axles	Mechanical Instrument Panel
Joystick Control(2 Spool)	Warm-air Machine

OPTIONAL EQUIPMENT

Cold Starting (-35°C)	Quick Hitch Coupler
Oil-bath Air Filter	Quick Hitch Bucket
23.5R25 ★★ L-3 TL	Bucket(3 Piece Cutting Edges)
23.5R25 ★★ L-5 TL	Rock Bucket(3.0m³)
Automatic Leveling&Limited Lifting Position	Enlarged Bucket(3.5m³)
3 rd Spool for Auxiliary Function	Coal Bucket(4.2m³)
Sliding Cabin Window	Log Grapple
Electric Heating Rear Window	Grass Grapple
Lockable Oil Tank Cap	Side Tip Bucket(2.5m³)
Rear View Camera	Marble Fork
Pressure Testing Connector	Log Fork
Air Conditioner	Close Sweeper
Radio/MP3	4in1 Bucket(Quick Hitch Only)
High Lift &Additional Counterweight	Snow Blade(Quick Hitch Only)

LONKING 龙工

Efficiency Rules the Future

ZL50NC WHEEL LOADER

POWERFUL WEICHAI ENGINE
LONKING TRANSMISSION
LONKING AXLES
JOYSTICK CONTROL
ROPS&FOPS CABIN
VARIETY WITH ATTACHMENT
CONVENIENT MAINTENANCE



■ RATED POWER:	162kW/2200rpm
■ BUCKET CAPACITY:	3.0 m³
■ RATED PAYLOAD:	5000kg
■ OPERATING WEIGHT:	17200kg

LONKING (FU JIAN) INTERNATIONAL TRADE CO.,LTD.

LONKING HOLDINGS LIMITED

Add:26 Minyi Road,Xinqiao,Songjiang Industrial Zone,Shanghai
P.C: 201612

Tel: +86-21-3760 2242

http://www.lonkinggroup.com

E-mail:export@lonking.cn

Lonking, Lonking CDM Series and their respective logos, as well as corporate identity in this leaflet are trademarks of Lonking Holdings Ltd. and may not be used without written permission.

2018/03

For more information on Lonking products,
Please contact our local agent:

Specifications and design are subject to change without prior notice.
Machines shown may not include optional accessories.